



ProV™ 200 Series Picture & Transom Parts Reference Catalog

#563175

FOR PRODUCT PRODUCED AFTER 05/94

Transom Direct Set



Picture Direct Set



Use with:

- 930 Single Hung
- 930 Double Hung
- 930 Gliding Window

PICTURE & TRANSOM

Mull/Stack

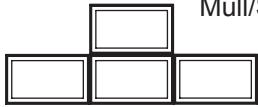

Use with:

- 930 Single Hung
- 930 Double Hung

NOTE: Gliding Windows CANNOT be mullled or stacked with the 930 Picture & Transom units OR with another Gliding Window.

MULL/STACK

Order Form



ORDER FORM

TABLE OF CONTENTS:

Mull/Stack Exploded View	1
Mull/Stack Replacement Parts/Accessories	2

DESCRIPTION:

All vinyl direct set window.

FRAME/SASH OPTIONS:

White or Sandtone

HARDWARE OPTIONS:

Screen frame and locks are color matched to window.

DISTINGUISHING FEATURES:

Full 3 1/4" main frame

HOW TO ORDER A PART:

Identify the part using the exploded views and indexes. Reference the part in the Picture & Transom Parts Reference Catalog #563173, using the number from the index.

When ordering replacement parts, unit must be viewed from the exterior.

GLASS IDENTIFICATION CODE:

The glass code number references the date of manufacture, which is helpful in identifying the product.

When ordering warranty replacement glass, sash or panels, it is necessary to specify the glass identification code. Markings are stamped on one of the four sides of the spacer channel which separates the two panes of glass. (Refer to the illustration at right)

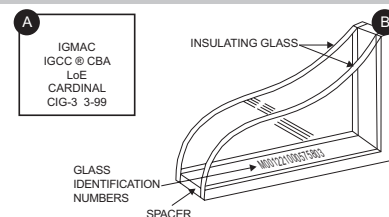

Markings are etched in the glass (A) or are printed/stamped on one of the four sides of the spacer channel which separates the two panes of glass (B).

MEASURING VISIBLE GLASS:

Typically, a part can be ordered by specifying catalog size or visible glass. The visible glass dimensions can be determined by measuring the width and the height of the exposed glass on the sash from inside the home. (Refer to arrows on the illustration at right)

Measurements within + or - 1/4" will be rounded to the nearest standard size as given in the tables on the Standard Catalog Size Charts. Visible glass dimensions that are greater or less than 5/16" of a standard size means it is a custom size window.

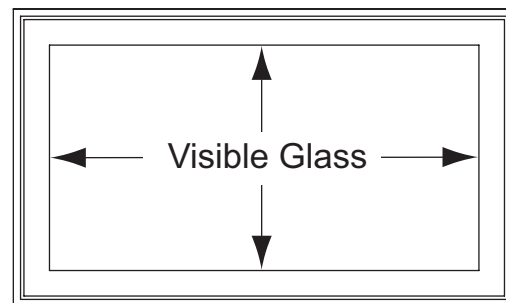

NOTE: 1/2" Spread Mull shown using the Mull Spacer Clip.
Half Round, Ellipse, and Eyebrow units are Tight Mullled using the Direct Mull Clip.

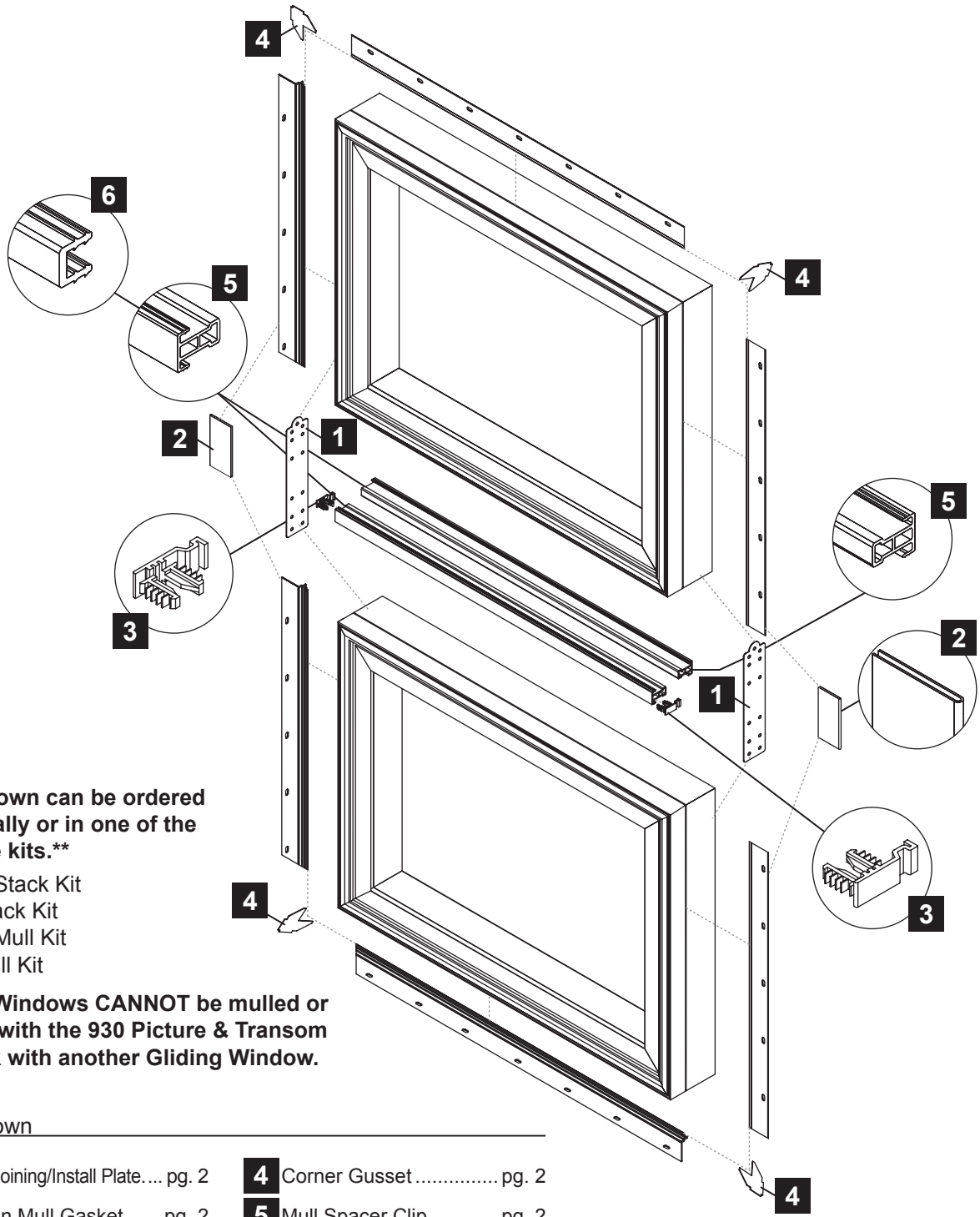

Parts shown can be ordered individually or in one of the available kits.**

- Spread Stack Kit
- Tight Stack Kit
- Spread Mull Kit
- Tight Mull Kit

Gliding Windows CANNOT be mullled or stacked with the 930 Picture & Transom units OR with another Gliding Window.

Parts Shown

1 Metal Joining/Install Plate.... pg. 2	4 Corner Gusset pg. 2
2 Nail Fin Mull Gasket pg. 2	5 Mull Spacer Clip pg. 2
3 Mull End Plug pg. 2	6 Direct Mull Clip pg. 2



Note: When ordering replacement parts, unit must be viewed from exterior.

Drawings not to scale.

MULL/
STACK

1 Metal Joining/Installation Plate

*Fasteners **Not** Included when this part is ordered by itself.*

STYLE: **MISC**

2 Nail Fin Mull Gasket

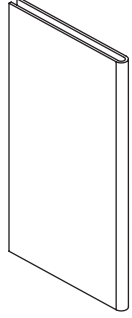

STYLE: **MISC**

3 Mull End Plug

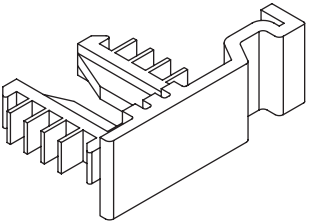

White
 Sandtone

Used only for Spread Mull/Stack.

STYLE: **MISC**

4 Corner Gusset (pkg. of 4)

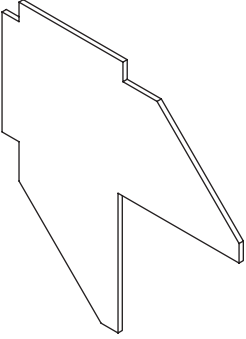

STYLE: **MISC**

5 1/2" Mull Spacer Clip

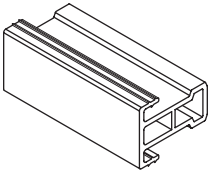
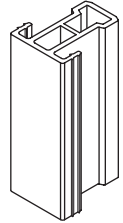



White
 Sandtone

Used only for Spread Mull/Stack.

STYLE: **AC**

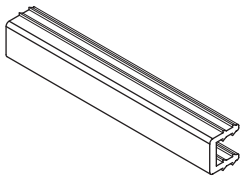
6 Direct Mull Clip

White
 Sandtone

Used only for Tight Mull/Stack.

STYLE: **AC**